

Attacks on Digital Watermarks: Classification, Estimation-Based Attacks, and Benchmarks

Sviatolsav Voloshynovskiy, Shelby Pereira, and Thierry Pun, University of Geneva

Joachim J. Eggers and Jonathan K. Su, University of Erlangen-Nuremberg

ABSTRACT

Watermarking is a potential method for protection of ownership rights on digital audio, image, and video data. Benchmarks are used to evaluate the performance of different watermarking algorithms. For image watermarking, the Stirmark package is the most popular benchmark, and the best current algorithms perform well against it. However, results obtained by the Stirmark benchmark have to be handled carefully since Stirmark does not properly model the watermarking process and consequently is limited in its potential for impairing sophisticated image watermarking schemes. In this context, the goal of this article is threefold. First, we give an overview of the current attacking methods. Second, we describe attacks exploiting knowledge about the statistics of the original data and the embedded watermark. We propose a stochastic formulation of estimation-based attacks. Such attacks consist of two main stages:

- Watermark estimation
- Exploitation of the estimated watermark to trick watermark detection or create ownership ambiguity

The full strength of estimation-based attacks can be achieved by introducing additional noise, where the attacker tries to combine the estimated watermark and the additive noise to impair watermark communication as much as possible while fulfilling a quality constraint on the attacked data. With a sophisticated quality constraint it is also possible to exploit human perception: the human auditory system in case of audio watermarks and the human visual system in case of image and video watermarks. Third, we discuss the current status of image watermarking benchmarks. We briefly present Fabien

Petitcolas' Stirmark benchmarking tool [1]. Next, we consider the benchmark proposed by the University of Geneva Vision Group that contains more deliberate attacks. Finally, we summarize the current work of the European Certimark project, whose goal is to accelerate efforts from a number of research groups and companies in order to produce an improved ensemble of benchmarking tools.

INTRODUCTION

Digital watermarking is a communication method in which information b is embedded directly and imperceptibly into digital data x (e.g., image, video, or audio signals), also called *original data* or *host data*, to form watermarked data y . Loosely analogous to watermarks in article documents, the embedded information is bound to the watermarked data wherever it goes. The embedded information should still be decodable from the watermarked data, even if the watermarked data is processed, copied, or redistributed. Potential applications of digital watermarking include copyright protection, distribution tracing, authentication, and conditional access control. Thus, the information b could be a user-ID, a serial number for a certain copy of a document, or authentication information.

We will concentrate our analysis on the copyright protection of still images, an urgent problem for modern e-commerce. Obviously, the attacks introduced in the article can be applied to audio and video watermarking algorithms with the safety of generality and technical modifications depending on the physics of the considered media.

The watermark can be regarded as an additive signal w , which contains the encoded and

modulated watermark message b under constraints on the introduced perceptible distortions given by a mask M so that

$$y = x + w(M).$$

Note that w need not be independent from the original data x . The simplest approach to achieve a perceptually indistinguishable watermarked and original signal is to keep the power of the watermark signal very low. Using sophisticated psycho-acoustic or psycho-visual models, more appropriate masks M can be applied to enhance the robustness of the watermarking scheme. Commonly used embedding techniques can be classified into *additive* [2], *multiplicative* [2], and *quantization-based schemes* [3, 4]. In additive schemes, there are usually very weak dependencies between w and x (e.g., introduced by choosing w dependent on a data-dependent perceptual mask M). In multiplicative schemes, samples of the original data are multiplied by an independent signal v so that $w = xv - x$. Here, w and x are of course dependent on each other. Strong local dependencies between the realizations of w and x exist in quantization-based watermarking schemes. However, these dependencies are such that statistically x and w appear (almost) independent.

The term *watermark* itself is not always well-defined in the literature. To be precise, we have to distinguish between the watermark signal w , which is the actual signal added to the original data, and the watermark message or information b that is conveyed by the watermark signal. Usually the meaning is clear from context. Coding schemes can be used to achieve reliable watermark communication. In some cases only one bit need to be communicated (on-off signaling), while in other cases a sequence of M -ary watermark symbols is transmitted.

In most watermarking applications, the marked data is likely to be processed in some way before it reaches the watermark receiver. The processing could be lossy compression, signal enhancement, or digital-to-analog (D/A) and analog-to-digital (A/D) conversion. An embedded watermark may unintentionally or inadvertently be impaired by such processing. Other types of processing may be applied with the explicit goal of hindering watermark reception. In watermarking terminology, an *attack* is any processing that may impair detection of the watermark or communication of the information conveyed by the watermark. The processed watermark data is then called *attacked data*.

An important aspect of any watermarking scheme is its robustness against attacks. The notion of robustness is intuitively clear: A watermark is robust if it cannot be impaired without also rendering the attacked data useless. Watermark impairment can be measured by criteria such as miss probability, probability of bit error, or channel capacity. For multimedia, the usefulness of the attacked data can be gauged by considering its perceptual quality or distortion. Hence, robustness can be evaluated by simultaneously considering watermark impairment and the distortion of the attacked data. An attack succeeds in defeating a watermarking scheme if it impairs the watermark beyond acceptable limits while maintaining the perceptual quality of the attacked data.

Since the complete theoretical analysis of the watermarking algorithm performance with respect to different attacks is rather complicated, the developers of watermarking algorithms refer to the results of experimental testing performed in the scope of some benchmark. The benchmark combines the possible attacks into a common framework and weights the resulted performances depending on the possible application of the watermarking technology.

This article discusses several state-of-the-art attacks that deliberately attempt to impair the watermark without excessively distorting the attacked data. Where possible, we take a general point of view to highlight attack principles that can be applied in many different circumstances. When it comes to practical examples, we usually refer to image watermarking since the background of the authors is strongest in this application area.

First, we briefly summarize state-of-the-art watermarking attacks and coarsely categorize them. Next, we discuss a relatively new direction: attacks based on watermark estimation. Combining the estimated watermark with additional noise in an optimized way can significantly improve the strength of attacks. Finally, three different approaches for benchmarking image watermarking schemes are presented.

STATE-OF-THE-ART WATERMARKING ATTACKS

One categorization of the wide class of existing attacks contains four classes of attacks: removal attacks, geometric attacks, cryptographic attacks, and protocol attacks. Here, we describe coarsely these four attack types and present some examples. More detailed descriptions can be found in [5, 6].

REMOVAL ATTACKS

Removal attacks aim at the complete removal of the watermark information from the watermarked data without cracking the security of the watermarking algorithm (e.g., without the key used for watermark embedding). That is, no processing, even prohibitively complex, can recover the watermark information from the attacked data. This category includes denoising, quantization (e.g., for compression), remodulation, and collusion attacks. Not all of these methods always come close to their goal of complete watermark removal, but they may nevertheless damage the watermark information significantly.

Sophisticated removal attacks try to optimize operations like denoising or quantization to impair the embedded watermark as much as possible while keeping the quality of the attacked document high enough. Usually, statistical models for the watermark and the original data are exploited within the optimization process.

Collusion attacks are applicable when many copies of a given data set, each signed with a key or different watermark, can be obtained by an attacker or a group of attackers. In such a case, a successful attack can be achieved by averaging all copies or taking only small parts from each different copy. Recent results show that a small number of different copies (e.g., about 10) in the hands of one attacker can lead to successful watermark removal.

In most watermarking applications, the marked data is likely to be processed in some way before it reaches the watermark receiver. The processing could be lossy compression, signal enhancement, or D/A and A/D conversion.

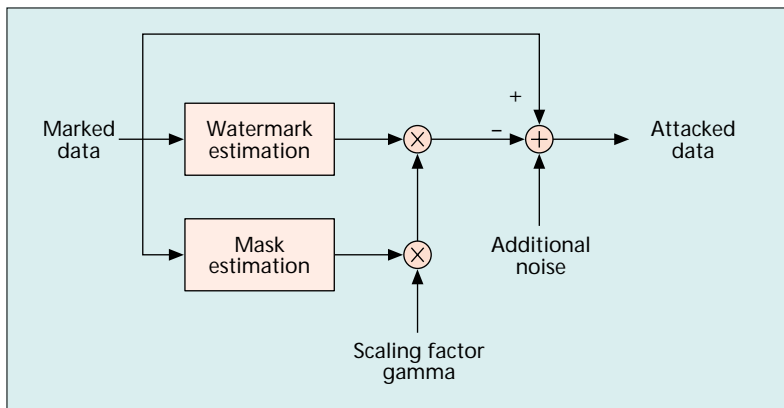

■ **Figure 1.** A perceptual remodulation attack.

GEOMETRIC ATTACKS

In contrast to removal attacks, *geometric attacks* do not actually remove the embedded watermark itself, but intend to distort the watermark detector synchronization with the embedded information. The detector could recover the embedded watermark information when perfect synchronization is regained. However, the complexity of the required synchronization process might be too great to be practical.

For image watermarking, the best known benchmarking tools, Unzign and Stirmark [1], integrate a variety of geometric attacks. Unzign introduces local pixel jittering and is very efficient in attacking spatial domain watermarking schemes. Stirmark introduces both global and local geometric distortions. We give a few more details about these attacks later in this article. However, most recent watermarking methods survive these attacks due to the use of special synchronization techniques. Robustness to global geometric distortions often relies on the use of either a transform-invariant domain (Fourier-Melline) or an additional template, or specially designed periodic watermarks whose autocovariance function (ACF) allows estimation of the geometric distortions. However, as discussed below, the attacker can design dedicated attacks exploiting knowledge of the synchronization scheme.

Robustness to global affine transformations is more or less a solved issue. However, resistance to the local random alterations integrated in Stirmark still remains an open problem for most commercial watermarking tools. The so-called random bending attack in Stirmark exploits the fact that the human visual system (HVS) is not sensitive to local shifts and affine modifications. Therefore, pixels are locally shifted, scaled, and rotated without significant visual distortion. However, it is worth noting that some recent methods are able to resist this attack.

CRYPTOGRAPHIC ATTACKS

Cryptographic attacks aim at cracking the security methods in watermarking schemes and thus finding a way to remove the embedded watermark information or to embed misleading watermarks. One such technique is brute-force search for the embedded secret information. Another attack in this category is the so-called Oracle

attack, which can be used to create a non-watermarked signal when a watermark detector device is available. Practically, application of these attacks is restricted due to their high computational complexity.

PROTOCOL ATTACKS

Protocol attacks aim at attacking the entire concept of the watermarking application. One type of protocol attack is based on the concept of *invertible watermarks* [7]. The idea behind inversion is that the attacker subtracts his own watermark from the watermarked data and claims to be the owner of the watermarked data. This can create ambiguity with respect to the true ownership of the data. It has been shown that for copyright protection applications, watermarks need to be noninvertible. The requirement of noninvertibility of the watermarking technology implies that it should not be possible to extract a watermark from a non-watermarked document. A solution to this problem might be to make watermarks signal-dependent by using one-way functions.

Another protocol attack is the *copy attack*. In this case, the goal is not to destroy the watermark or impair its detection, but to estimate a watermark from watermarked data and copy it to some other data, called *target data* [8]. The estimated watermark is adapted to the local features of the target data to satisfy its imperceptibility. The copy attack is applicable when a valid watermark in the target data can be produced with neither algorithmic knowledge of the watermarking technology nor knowledge of the watermarking key. Again, signal-dependent watermarks might be resistant to the copy attack.

ESTIMATION-BASED ATTACKS

Here, we consider attacks that take into account the knowledge of watermarking technology and exploit statistics of the original data and watermark signal [5, 9–12]. In addition, we emphasize that for the design of attacks against watermarking schemes, the distortion of the attacked document and the success of watermark impairment has to be considered. Within the scope of these attacks, we present the concept of *estimation-based attacks*. This concept is based on the assumption that the original data or the watermark can be estimated — at least partially — from the watermarked data using some prior knowledge of the signals' statistics. Note that estimation does not require any knowledge of the key used for watermark embedding. Furthermore, knowledge of the embedding rule is not required, but the attack can be more successful with it.

Depending on the final purpose of the attack, the attacker can obtain an estimate of the original data or of the watermark based on some stochastic criteria such as maximum likelihood (ML), maximum a posteriori probability (MAP), or minimum mean square error (MMSE). We do not focus here on the particularities of the above estimation but rather concentrate on different ways to exploit the obtained estimates to impair the embedded watermark. Depending on the way the estimate is used, we can classify estimation-based attacks as removal, protocol, or desynchronization attacks.

ESTIMATE OF THE ORIGINAL DATA

Considering the watermark as noise in the watermarked data, the attacker can try to estimate the original unwatermarked data. This attack results in the design of an optimal denoising scheme. Taking into account the results of recent investigation that established the strong connection between denoising and compression for filtering of additive noise from the images, this means in the case of image watermarks that the attacker can easily apply the most recent advanced coders based on wavelet decompositions to remove the watermark. Keeping in mind the design of such coders in terms of an optimal rate-distortion trade-off, the attacker can obtain a considerable gain in resolving the compromise between distortions introduced by the attack and success in removal of the watermark. Note that in both denoising and optimized compression, both the perceptual and objective quality of the attacked image can be improved significantly. We classify both denoising and optimized compression as removal attacks.

REMULATION ATTACKS

Remodulation attacks aim at modification of the watermark using modulation opposite to that used for watermark embedding. Assuming the estimated watermark is correlated with the actual watermark, meaning a good estimate could be obtained, the estimated watermark can be subtracted from the watermarked data. Subtracting a very inaccurate estimate of the watermark might decrease the document quality without affecting the watermark too much. On the other hand, correlation-based detection can be defeated by subtracting an amplified version of the estimated watermark. For this reason, we introduced a gain factor $\gamma \geq 1$, which gives us the possibility to trade off the distortion of the attacked document vs. the success of the attack.

There are four basic variations of the remodulation attack. First, when $\gamma = 1$, the attack yields the MMSE/MAP estimate of the original and reduces to the denoising attack. Second, for $\gamma > 1$, the quality of the attacked document might be reduced, but correlation-based detection might be defeated more successfully. The attack can even drive the correlation to zero so that the detector incorrectly decides that the watermark is not present in the attacked data.

Third, when using a more sophisticated distortion measure than simple MSE, a better compromise between success of the attack and introduced distortion can be obtained by weighting the remodulated watermark by a perceptual mask. Fourth, the attacker can not only subtract the weighted, estimated watermark, but also add outliers to obtain a non-Gaussian noise distribution, which decreases the performance of correlation-based detection. Moreover, exploiting features of the human perceptual system, the attacker can efficiently embed a large amount of outliers in perceptually less significant parts of the data. For image data, this approach has been demonstrated to be successful in [9]. We refer to this attack as *perceptual remodulation* (Fig. 1).

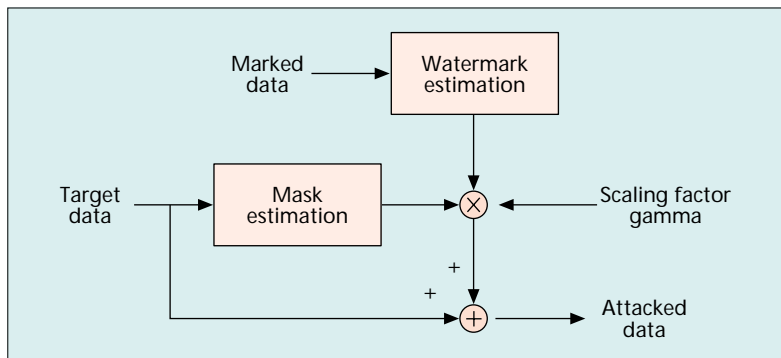

Figure 2. A copy attack.

COPY ATTACK

The estimated watermark can be exploited to implement a copy attack, as already described. Of course, the copied watermark has to be adapted to the target data to keep the quality of the falsely watermarked target data high enough. There are many practical ways to adapt the watermark to the target data based on perceptual models. For images, contrast sensitivity and texture masking phenomena of the HVS can be exploited. The estimation-based copy attack is most successful when the same perceptual model is used as in the original watermarking algorithm.

Note that the copy attack in its described version is mainly applicable to additive watermarking schemes. In the case of quantization-based watermarking schemes, even a perfectly estimated watermark signal w cannot be copied since it is highly unlikely that the copied signal w is a valid watermark in the target signal (Fig. 2).

SYNCHRONIZATION REMOVAL

Watermark estimation can also be very efficiently applied to attack synchronization mechanisms. The basic idea of *synchronization removal* is to detect synchronization patterns, remove them, and then apply desynchronization techniques, such as global affine transformation in the case of image watermarking.

Here, we concentrate on synchronization methods for image watermarking based on a template in the magnitude image spectrum or on the ACF of periodic watermarks. In both cases, peaks are generated in the Fourier domain [5, 9]. It is obvious that such peaks can easily be detected. Once the peaks have been detected, the next step of the attack is to interpolate the spectrum of the watermarked image or previously attacked image in the locations of spatial frequencies determined by a local peak detector. The generalized block diagram of this attack is shown in Figure 3, where \mathfrak{F} and \mathfrak{F}^{-1} denote direct and inverse Fourier transforms, respectively, $|\cdot|$ is the magnitude, and \arg is the phase.

COUNTERMEASURES AGAINST ESTIMATION-BASED ATTACKS

To resist estimation-based attacks, the embedder aims at making the watermark difficult to estimate. This approach has been investigated for two different scenarios.

If distortion is measured by the mean-squared difference between the attacked data and the unwatermarked, original data, then the PSC has another important consequence: For any output of the matched filter, a watermark that fulfills the PSC causes the above attack to incur the greatest distortion.

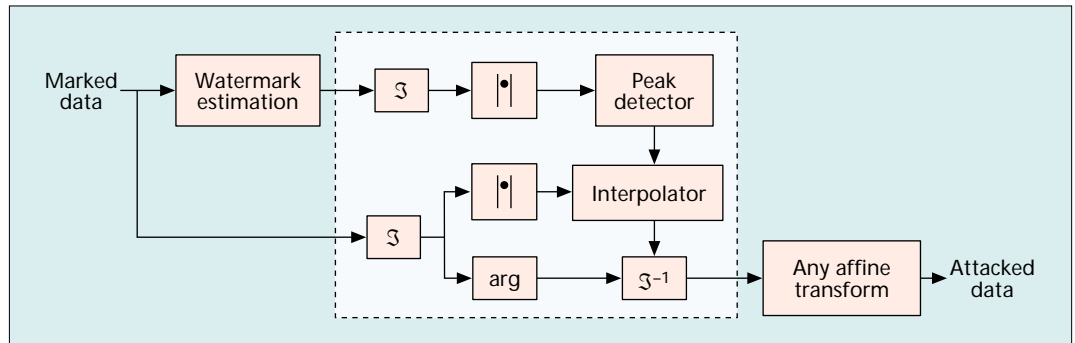

■ Figure 3. A synchronization removal attack.

Power-Spectrum Condition — An idealized theoretical approach [10] for analyzing estimation-based attacks treats the original signal and watermark as independent, zero-mean, stationary, colored Gaussian random processes. The watermarked data is the sum of these two processes. Since the original signal is given, its power spectrum is assumed to be fixed, but the watermark power spectrum can be varied. The question is, how should the watermark power spectrum be shaped to resist an estimation-based attack? For this scenario, the optimal estimate is obtained by a Wiener filter.

The MSE E between the original watermark and the estimated watermark provides a convenient way to measure how well a watermark resists estimation. It can be shown that E is maximized if and only if the watermark power spectrum is directly proportional to the power spectrum of the original signal. This requirement is called the *power-spectrum condition* (PSC). A watermark whose power spectrum satisfies the PSC is the most resistant against estimation.

If distortion is measured by the mean squared difference between the attacked data and the unwatermarked original data, the PSC has another important consequence: For any output of the matched filter, a watermark that fulfills the PSC causes the above attack to incur the greatest distortion. To drive the correlation to zero, the attack must make the distortion as large as the power of the original data, so the attacked data is unlikely to be useful.

Noise Visibility Function — The PSC is attractive because it can be proven rigorously and has a convenient mathematical form. For image watermarking, image denoising provides a natural way to develop estimation-based attacks [13] optimized for the statistics of images, although optimality might be difficult to prove. The watermarked image is treated as a noisy version of the original image, and the watermark represents noise that should be eliminated. Thus, the estimated watermark is the same as the estimated noise.

We applied different statistical models for the original images, namely a nonstationary Gaussian process or a stationary, generalized Gaussian process. The noise/watermark can be treated as one of these processes; however, here we assume that it is still a stationary Gaussian process. In the first case, the denoising method uses an adaptive Wiener filter, while in the second it reduces to the popular denoising methods of hard-threshold-

ing and soft-shrinkage as particular cases.

Both denoising methods produce a *texture masking function* (TMF), which is derived from the image statistics and is therefore image-dependent. The TMF takes on values in [0,1]. To embed a watermark that resists such estimation, the watermark embedding should use the inverted function known as a *noise visibility function* (NVF), defined by $NVF = 1 - TMF$. NVF values near unity indicate flat regions, where the watermark should be attenuated, while NVF values near zero indicate texture or edge regions, where the watermark should be amplified. In this way, the watermark is embedded to resist estimation-based attacks derived from image denoising.

A qualitative comparison sheds light on the structure of watermarks produced in this manner. Figure 4a shows the original Cameraman image and the NVFs derived using the first and second cases, and Fig. 4b depicts the corresponding magnitude spectra. The figure clearly shows that the resulting watermark spectra are closely matched to the power spectrum of the original image. Note that for images, the PSC can give only a coarse result since the underlying statistical model does not fit very closely to images. Nevertheless, the results obtained using the PSC agree with those of the NVF. The two approaches complement each other well. These results support the heuristic argument of Cox *et al.* [2] that the watermark should be placed in the “perceptually significant frequency components.”

ATTACKS DEPENDENT ON LOCAL SIGNAL STATISTICS

Different estimation-based attacks can successfully be combined depending on local signal statistics. Here we focus on image watermarking. The attacker is motivated to reduce the maximum rate of reliable communication also by exploiting the HVS and the possibility to remove the watermark based on different models of the image. The watermark can easily be predicted and removed from flat image areas rather than from areas of edges and textures. The stochastic model for the edges and textures is nonstationary and relatively complicated to use for accurate image estimation. Therefore, the attacker will try as much as possible to utilize the advantages of denoising and remove the watermark from flat areas without visual distortions and even enhancing the PSNR. In contrast, the attacker will use remodulation with increased

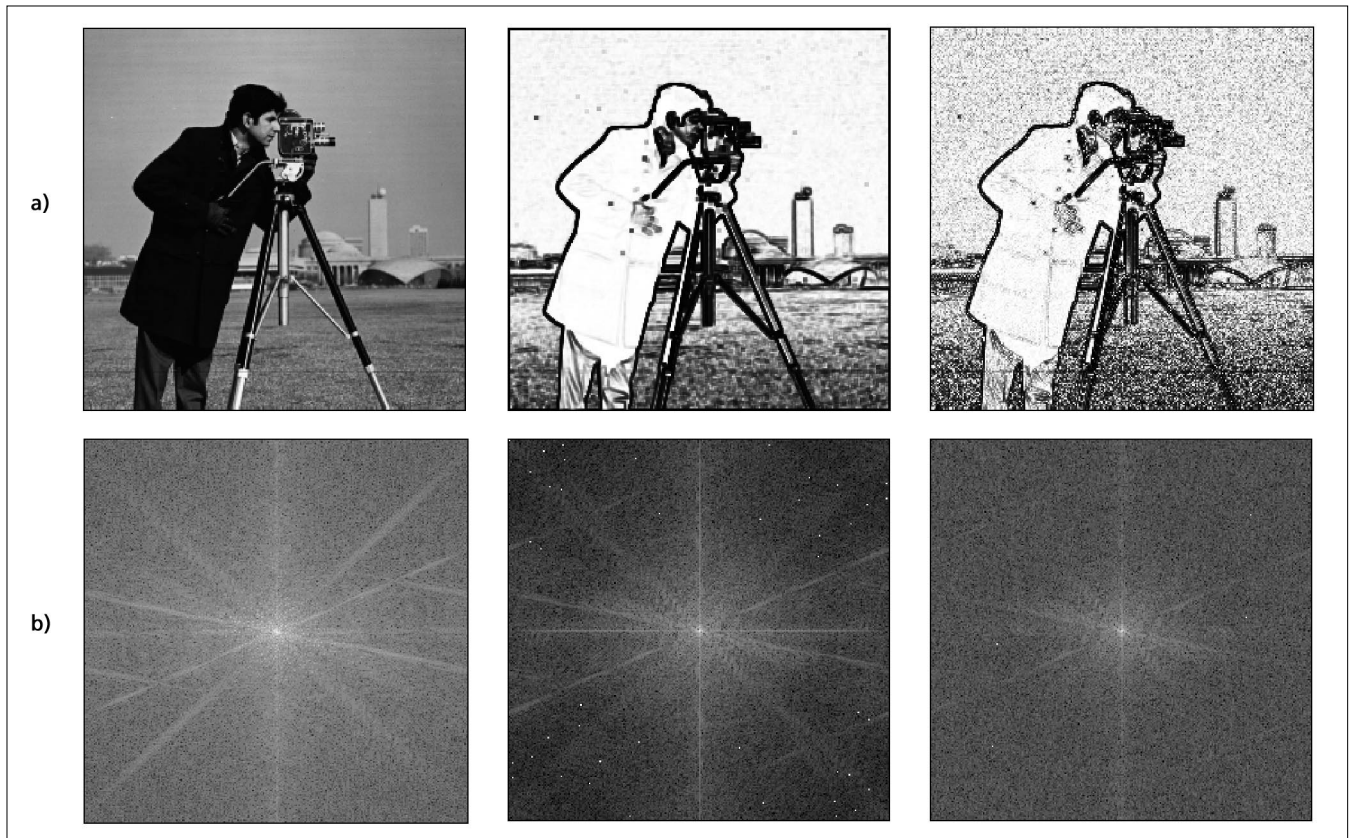

Figure 4. a) From left to right: original image, and NVF estimated based on the nonstationary Gaussian and stationary generalized Gaussian image models; b) corresponding spectra.

strength in the edges and texture areas, which again will be masked by the HVS. At the same time, the attacker can use the NVF to automatically determine the flat regions, edges, and textures. This attack is schematically shown in Fig. 5b. The practical power of this attack was first demonstrated in [9], and a further theoretical analysis can be found in [5, 12].

OPTIMIZED ATTACKS

So far, we have developed different attacks based on watermark estimation and discussed how an embedder can make watermark estimation as difficult as possible. However, the embedder has another chance to react to estimation-based attacks, especially to the remodulation attack. The detector can first estimate the remodulated watermark and try to invert the remodulation, and thus retain reliable watermark detection. For instance, when watermark estimation is based on Wiener filtering, the detector can apply inverse Wiener filtering. This is of course not wanted by the attacker. Thus, he/she has to add noise to the attacked data, which would be amplified by the inverse Wiener filtering and thus impair watermark detection. Of course, the additive noise further degrades the attacked signal.

Now, we have the situation where the attacker has to find a good combination of using the estimated watermark and the noise to be added. The embedder no longer simply tries to make watermark estimation as hard as possible, however; he also has to get a power advantage over

the additive noise an attacker might introduce. This problem can be formulated in an even more general way: the attacker attempts to minimize the watermark capacity under a constraint on the distortions introduced by the attack. The embedder attempts to maximize the watermark capacity under a constraint on the embedding distortions. This situation can be regarded as a game between the attacker and embedder. To solve this problem, we followed a game-theoretic approach, assuming that the embedder and attacker know each other's behavior [11, 12].

We consider the scenario where the original signal and watermark are drawn from independent, zero-mean, stationary, colored Gaussian random processes. In this case a solution to the described game can be found. It appears that the optimal watermark power allocation for reliable watermarking is dependent on the amount of distortion that can be introduced by an attacker. At low distortion levels, white watermarks perform near optimally, while at high distortion, PSC-compliant watermarks are more appropriate. Watermarks embedded into signal components with low variance (e.g., high frequencies or flat regions in images) will be filtered out by the optimized attacks, while watermarks embedded into signal components with high variance are more efficiently disturbed by additive noise. To apply these results to real-world watermarking applications, good signal decompositions have to be used to separate signal components with different statistics. For images, wavelet decomposition might be a good choice. However, research in this direction is still inconclusive.

Watermarks embedded into signal components with low variance (e.g., high frequencies or flat regions in images) will be filtered out by the optimized attacks, while watermarks embedded into signal components with high variance are more efficiently disturbed by additive noise.

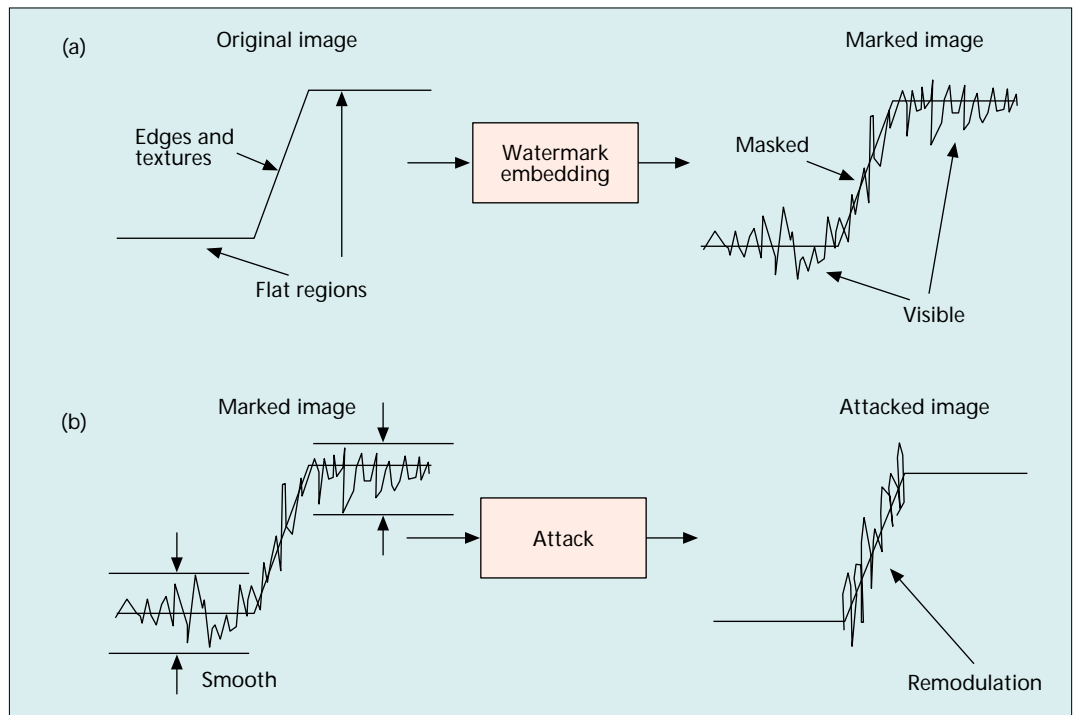

■ **Figure 5.** a) The data hider strategy exploiting the texture masking function of the HVS; b) the attacker strategy using denoising and perceptual remodulation.

BENCHMARKING

In this section we present three benchmarking initiatives for image watermarking schemes: Stirmark [1], a benchmark including estimation-based attacks as proposed in [5], and the current Certimark initiative.

STIRMARK

The Stirmark benchmark [1] divides attacks into the following nine categories: signal enhancement, compression, scaling, cropping, shearing, rotation, linear transformations, other geometric transformations, and random geometric distortions. In the case of signal scaling, cropping, shearing, rotation, linear transformations, and other geometric transformations, the attacked images are obtained with and without JPEG 90 percent quality factor compression. In order to produce a score relative to the benchmark, a score of 1 is assigned when the watermark is decoded and 0 when it is not decoded. The average is then computed for each category, and the average of the results is computed to obtain an overall score. The benchmark should also be averaged over several images. In order to ensure a fair comparison, Petitcolas suggests imposing a minimum PSNR of 38 dB for the watermarked image. However, this constraint is questionable since PSNR is not a meaningful measurement in the context of geometric distortions.

A BENCHMARK INCLUDING ESTIMATION-BASED ATTACKS

While the Stirmark benchmark is an excellent tool for measuring the robustness of watermarking algorithms, it is heavily weighted toward geometric transformations, which do not take into

account prior information about the watermark. Therefore, another benchmark was proposed [5], which contains the following six categories of attacks:

- Denoising: Wiener filtering, soft shrinkage, and hard thresholding.
- Denoising followed by perceptual remodulation.
- Denoising followed by Stirmark random bending.
- Copy attack: The watermark is estimated using Wiener filtering and copied onto another image. If the watermark is successfully detected in the new image, the algorithm has failed.
- Template removal followed by small rotation.
- Compression based on wavelet decomposition of the image, which is superior to JPEG compression and is integrated to reflect the future appearance of the JPEG2000 standard.

Also included in this benchmark is a new proposal for evaluating image quality. Rather than using PSNR, two approaches based on weighted PSNR and Watson's metric are proposed. The Watson metric measures local image characteristics and reflects luminance, contrast, and texture masking.

CERTIMARK

The lack of officially accepted benchmarking tools fastened the launch of the European project Certimark (Certification for Watermarking techniques) that started in May 2000. The project includes 15 academic and industrial partners. The objectives of Certimark are:

- To design, develop, and publish a complete benchmark suite for watermarking technolo-

- gies within promising application scenarios
- To make this benchmark suite a reference tool for technology suppliers and technology customers within promising applications scenarios
- To set up a certification process for watermarking algorithms
- To concentrate research on pending key issues in watermarking for protection of still images and low-bit-rate video over the Internet

The aim of Certimark, based on the benchmark reference, is to make watermarking algorithms labeled with an international certification. This certification process and award will be conducted by a major international rights holder representative. Benchmarking, leading to an internationally recognized reference, will permit customers to assess the appropriateness of a given watermarking technology for their needs. Assessment of technologies in a clear framework will allow competition between technology suppliers while maintaining a given quality standard as measured by the benchmark. In summary, the originality and emphasis of the project will be on the parallel development of objective evaluation tools and robust watermarking techniques to be certified in order to win the confidence of content providers.

CONCLUSIONS

Attacks on digital watermarking systems are investigated in this article. First, a categorization of different attacks is given, and popular attacks are briefly described. We point out that attacks on digital watermarks must consider both watermark survival and the distortion of the attacked document. Early attacks do not exploit as much knowledge of the watermarking scheme as possible; also, they do not consider the distortion of the attacked document. Since attacks can be improved by using knowledge of the watermarking scheme and the signal statistics, we describe a new set of attacks called estimation-based attacks. The general idea is to estimate the watermark and exploit it to trick the detector. It is shown that this approach is related to denoising, but can be extended to a variety of different attack methods. Next we describe how an embedder can try to resist estimation based attacks, which leads to the concept of PSC-compliant watermarks or watermarks adapted to the NVF, depending on the application and signal model at hand. Finally, we explain how considering the watermarking and attacking problem as a game between embedder and attacker can be exploited to find the watermark capacity, when facing an optimized attack with a constrained attack distortion. The theoretical analysis of watermark attacks gives many insight into the watermarking problem, and enables us to show fundamental limits of this technology. However, theory does not render benchmarks of practical watermarking algorithms useless. On the contrary, both concepts complement each other. Therefore, we described and compared some recent watermark benchmark initiatives in the last part of the article.

REFERENCES

- [1] M. Kutter and F. Petitcolas, "A Fair Benchmark for

- Image Watermarking Systems," *Electronic Imaging '99: Security and Watermarking of Multimedia Content*, SPIE Proc., vol. 3657, San Jose, CA, Jan. 1999.
- [2] I. Cox et al., "Secure Spread Spectrum Watermarking for Multimedia," *IEEE Trans. Image. Proc.*, vol. 6, no 12, Dec. 1997, pp. 1673-87.
- [3] B. Chen and G. W. Wornell, "Dither Modulation: A New Approach to Digital Watermarking and Information Embedding," *Security and Watermarking of Multimedia Contents, Proc. SPIE*, vol. 3657, San Jose, CA, Jan. 1999.
- [4] J. J. Eggers, J.K. Su, and B. Girod, "A Blind Watermarking Scheme Based on Structured Codebooks," *IEE Colloq.: Secure Images and Image Authentication*, London, UK, Apr. 2000.
- [5] S. Voloshynovskiy et al., "Attack Modeling: Towards a Second Generation Watermarking Benchmark," *Sig. Processing*, Special Issue on Information Theoretic Issues in Digital Watermarking, 2001.
- [6] F. Hartung, J. K. Su, and B. Girod, "Spread Spectrum Watermarking: Malicious Attacks and Counter-Attacks," *Security and Watermarking of Multimedia Contents, Proc. SPIE*, vol. 3657, San Jose, CA, Jan. 1999.
- [7] S. Craver et al., "On the Invertibility of Invisible Watermarking Techniques," *Proc. IEEE Int'l. Conf. Image Processing 1997*, vol. 1, pp. 540-43.
- [8] M. Kutter, S. Voloshynovskiy, and A. Herrigel, "Watermark Copy Attack," *IS&T/SPIE's 12th Annual Symp., Electronic Imaging 2000: Security and Watermarking of Multimedia Content II*, P. W. Wong and E. J. Delp, Eds., SPIE Proc., vol. 3971, San Jose, CA, Jan. 2000.
- [9] S. Voloshynovskiy et al., "Generalized Watermark Attack Based on Watermark Estimation and Perceptual Remodulation," *IS&T/SPIE's 12th Annual Symp., Electronic Imaging 2000: Security and Watermarking of Multimedia Content II*, P. W. Wong and E. J. Delp, Eds., SPIE Proc., vol. 3971, San Jose, CA, Jan. 2000.
- [10] J. K. Su and B. Girod, "Power-Spectrum Condition for Energy-Efficient Watermarking," *Proc. IEEE ICIP '99*, Oct. 1999.
- [11] J. K. Su, J. J. Eggers, and B. Girod, "Analysis of Digital Watermarks Subjected to Optimum Linear Filtering and Additive Noise," *Sig. Processing*, Special Issue on Information Theoretic Issues in Digital Watermarking, 2001.
- [12] P. Moulin and J. O'Sullivan, "Information-Theoretic Analysis of Information Hiding," submitted to *IEEE Trans. Info. Theory*.
- [13] S. Voloshynovskiy et al., "A Stochastic Approach to Content Adaptive Digital Image Watermarking," *Int'l. Wksp. Info. Hiding*, vol. LNCS 1768, *Lecture Notes in Comp. Sci.*, Springer Verlag, 29 Sept. -1 Oct. 1999, pp. 212-36.
- [14] A. B. Watson, "DCT Quantization Matrices Visually Optimized for Individual Images," *Proc. SPIE: Human Vision, Visual Processing and Digital Display IV*, vol. 1913, 1993, pp. 202-16.

BIOGRAPHIES

SVIATOLSAV VOLOSHYNOVSKIY (svolos@cui.unige.ch) received a radio engineer degree from the Lviv Polytechnic Institute in 1993, and a Ph.D. in radio engineering and television systems from State University Lvivska Polytechnika, Ukraine, in 1996. He immediately started as assistant professor at the above University. In 1998 he was at the Coordinated Science Lab, University of Illinois at Urbana-Champaign as a visiting scholar. Currently he is a research assistant professor at the University of Geneva, Switzerland, and an associate professor at State University Lvivska Polytechnika. He has over 70 journal and conference papers, and four patents in radar imaging, smart antenna arrays, image restoration, steganography, and digital watermarking.

SHELBY PEREIRA (shelby.pereira@cui.unige.ch) received a Bachelor's degree in electrical engineering in 1995. He then completed a Master's in biomedical engineering at Ecole Polytechnic in Montreal in 1997 where his research considered image restoration problems in tomography. He received a Ph.D. from the University of Geneva in computer science in 2000. He is currently a senior researcher at the same university. Research interests include image watermarking, attacks on watermarking systems, spread spectrum communications, detection, and estimation theory.

THIERRY PUN (thierry.pun@cui.unige.ch) obtained his Ph.D. in image processing in 1982 from the Swiss Federal Institute of

The lack of officially accepted benchmarking tools fastered the launch of the European project Certimark that started in May 2000. The project includes 15 academic and industrial partners.

The theoretical analysis of watermark attacks gives many insight into the watermarking problem, and enables us to show fundamental limits of this technology.

Technology in Lausanne (EPFL). He joined the University of Geneva, Switzerland, in 1986, where he is currently a full professor in the Computer Science Department. Since 1979 he has been active in various domains of image processing, image analysis, and computer vision. He has authored or co-authored over 150 journal and conference papers and three patents in these areas, and led or participated in a number of national and European research projects. His current research interest is focused on several aspects of the design of multimedia information systems: image and video content-based information retrieval systems, a Web browser for blind users, and image and video watermarking.

JOACHIM J. EGGERS (egggers@LNT.de) received a Dipl.-Ing. in electrical engineering from the University of Technology (RWTH), Aachen, Germany, in 1998. Since 1998 he has been a member of the Image Communication Group at the Telecommunications Laboratory of the University of Erlangen-Nuremberg, Germany, where he is working toward his Ph.D. His research interests include digital watermarking of multimedia data, attacks on digital watermarks, and information-theoretic aspects of digital watermarking.

JONATHAN K. SU (SU@LNT.DE) received a Ph.D. degree from the Georgia Institute of Technology in 1997. In 1998 he joined the Telecommunications Laboratory at the University of Erlangen-Nuremberg, Germany, as a member of research staff. In October 2000, he joined MIT Lincoln Laboratories in Lexington, Massachusetts. His research interests include digital image and video compression, digital watermarking and information hiding, human visual perception, and optimal estimation. He was co-presenter of the tutorial on image and video watermarking at the 2000 IEEE International Conference on Image Processing in Vancouver, British Columbia, Canada. He served as co-chair of the 1999 Deutsche Forschungsgemeinschaft (DFG) V3D2 Watermarking Workshop in Erlangen, Germany, and is co-author of the book *Introduction to Optimal Estimation* (Springer 1999). He is a member of Phi Beta Kappa, Sigma Xi, Tau Beta Pi, and Eta Kappa Nu.